

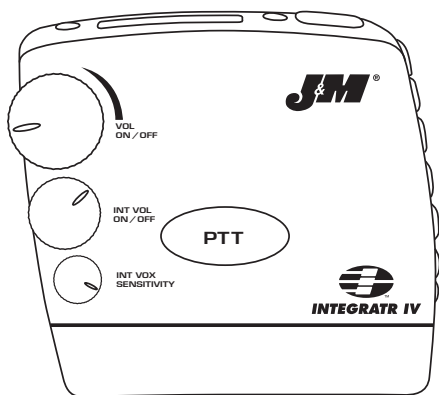

Quality Motorcycle Audio



# INTEGRATR™ IV



**Portable Motorcycle  
Audio System**

## **Installation and Operation Instructions**

The Integratr IV has been developed to provide motorcycle riders with the most advanced audio and communications system available. The Integratr IV allows owners to utilize privately purchased portable modular electronic devices such as cell phones, two way radios, portable music storage devices (MP3/IPOD), along with navigation (GPS)/highway warning audio devices.

The Integratr IV manages all audio sources as well as communications with a passenger and other individuals, whether on motorcycles or other vehicles. There are many choices available, so it is important to fully understand how to manage these options to bring the highest level of enjoyment to you and your passenger. Please read the enclosed manual completely. The manual provides an overview of the audio & communications system, a detailed explanation how each interface operates, and provides an understanding of options / accessories available to maximize your enjoyment of the system.

### **Overview**

The audio management of the Integratr IV consists of inputs and outputs from numerous standard and optional devices. To gain the most benefit from the system, it is necessary to understand what functions are available. As with all audio systems, these devices operate on different levels, which determine what priority each level has over the other. These levels go from lowest priority (level 1) to highest priority (level 4).

**Level 1** - Music can be received into the helmet headsets using one of the sources listed below:

- Built in FM Stereo Radio

or

- Auxiliary Audio Input (MP3 players/IPOD Etc.)

**Level 2** - Driver / passenger intercom, which mutes level 1 audio when engaged.

The Integratr IV intercom is also engaged when a signal is received from:

- FRS/GMRS radios (462 MHz two-way radios from Kenwood, Motorola, etc.)

**Level 3** - Cell Phone, which mutes all level 2 and lower functions (except intercom), connecting rider and passenger helmet headsets to the cell phone.

**Level 4** - Warning device will interrupt all lower levels (for Right helmet speaker only), to signal:

- Accessory Audio Warning Device (equipped with audio output jack)

or

- Navigation (GPS) device (equipped with audio output jack)

The Integratr IV also provides the connection jacks for the rider /passenger headsets for all of the functions noted above. The Integratr IV has been optimized to provide excellent music fidelity for your listening enjoyment.

## Controls and Functions

### Diagram A

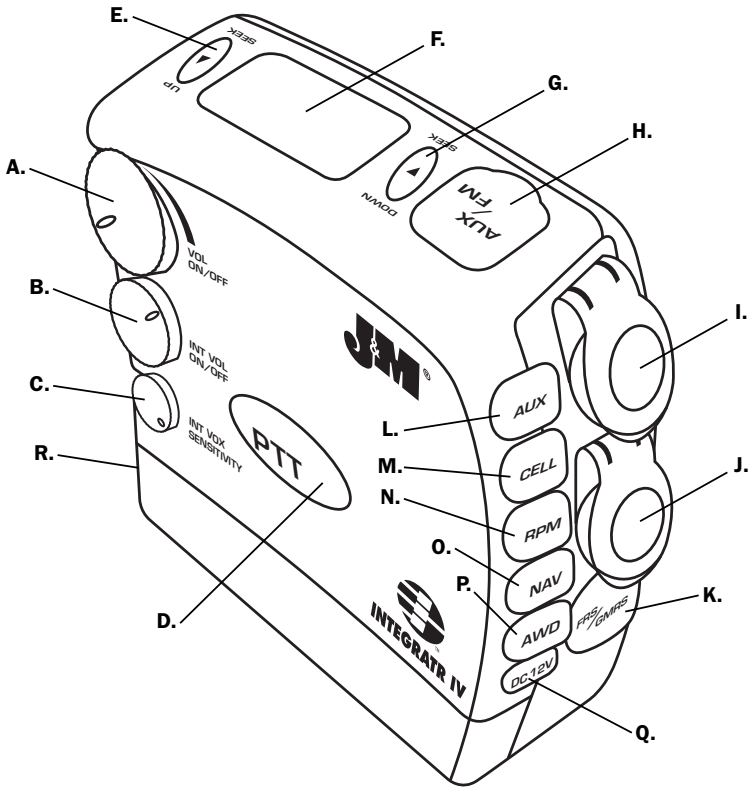

- A.** On/Off Music Volume Control
- B.** Intercom Volume On/Off Control
- C.** Intercom Vox Sensitivity Control
- D.** PTT Switch
- E.** Seek Up
- F.** LCD Display
- G.** Seek Down
- H.** Aux/FM Music Selector Switch
- I.** Drivers Helmet Headset Jack

- J.** Passengers Helmet Headset Jack
- K.** FRS/GMRS Jack
- L.** Auxiliary Audio Input
- M.** Cell Phone Input
- N.** Remote Push to Talk/Mute Input
- O.** Navigation Input
- P.** Auxiliary Warning Device Input
- Q.** DC 12v Accessory Output
- R.** Battery Release

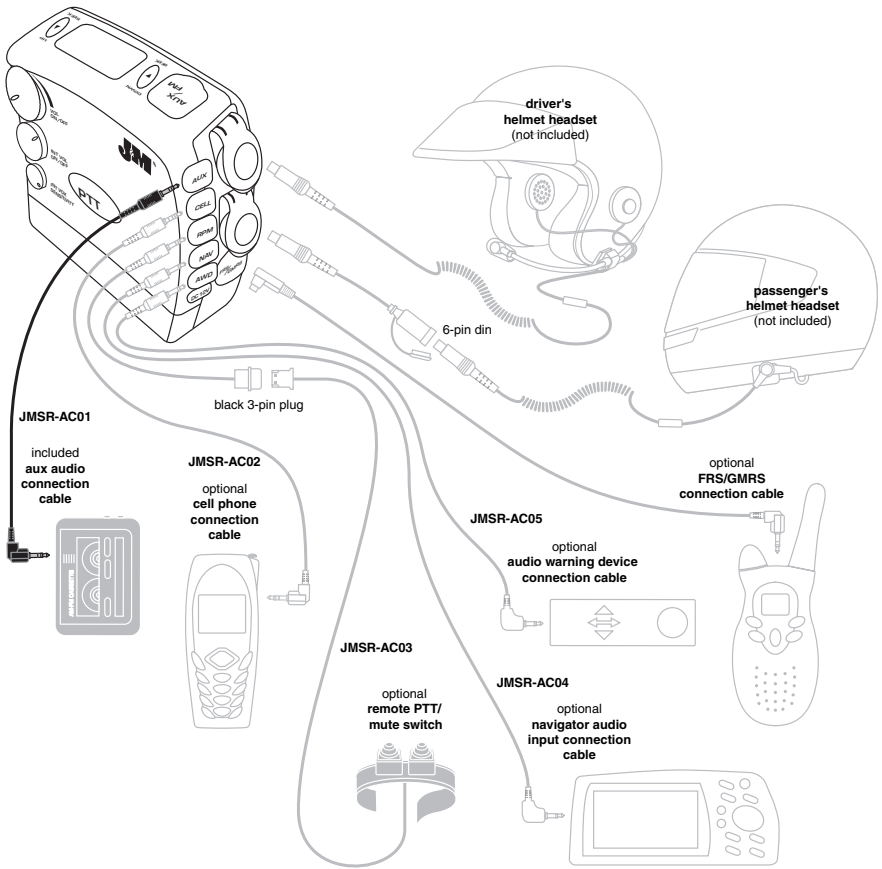

## SET-UP

- 1) Install Alkaline batteries into the battery tray and slide the tray onto the bottom of the Integratr IV.
- 2) Place the Integratr IV in the included belt pouch or your tank bag.

## Auxiliary Audio Input

The Integratr IV provides a port to connect auxiliary audio players (such as MP3/IPOD devices) to the audio channel (Level 1).

- Connect the accessory audio device using the connection cable J&M Part# JMSR-AC01.
- Select Aux input with the Aux/FM switch (H)
- Adjust the audio volume of the accessory audio device to a comfortable level, as the audio is feeding directly into the Integratr IV.

## **Rider / Passenger Intercom**

### **Operation**

- The Integratr IV intercom is a voice activated system that allows seamless communication between rider and passenger. The Integratr IV intercom is operational when the master volume on / off switch is turned "on".

### **Requirements**

- The Integratr IV will function properly only if the rider and passenger are wearing helmets outfitted with J&M Dual-Mode helmet headsets along with the proper lower section hook-up cords.

### **Operation Guidelines**

- Set the intercom volume control (B) to 50% of range to ensure that audio is not excessively loud when system is turned-on. You may later adjust the volume to the desired level, turning it clockwise to increase the volume.
- Adjust the VOX sensitivity knob (C) to the desired level that will allow the intercom to activate upon speaking, but not falsely activate from outside ambient / wind noise. Turn clockwise for greater sensitivity, counterclockwise for less sensitivity.
- The intercom will mute the music from all audio sources when VOX is engaged, and return the music 3.5 seconds after the last VOX input is received. The 3.5 second delay spans the natural gaps that occur from voice inflections and minor turns of the head (away from microphone) that occur while riding.
- The optional rider / passenger PTT switch will also activate the intercom, thus allowing both the rider and passenger the enjoyment of duplex communication when using two-way radios.

### **Note:**

For maximum enjoyment of the system, it is important that the helmet headset microphone placement be correct, as advised in the headset installation instructions. Too much gap between the mouth and microphone will result in excessive noise entering the system and imperfect intercom operation / VOX switching.

### **Cellular Telephone**

The Integratr IV provides an input for cellular phone communication. Given the increased emphasis/local legislation requiring the use of cellular phone headsets while driving a car, as well as the proliferation of phone models and calling plans available, J&M is providing a simple connection to the Integratr IV via the cellular phone headset 2.5 mm jack found on most phones. If your phone does not have a headset jack, consult your phone supplier for an accessory headset adapter.

- Using the cellular phone cable JMSR-AC02 plug the 3.5 mm plug into (M) to the Integratr IV cell phone jack and the 2.5 mm plug into your cellular phone headset jack. (JMSR-AC92 adapter is available for 4-pin style Nokia Phones.)
- Consult your cellular phone owners manual to set your telephone to auto-answer. This will allow you to receive calls while riding, without the need to touch or manipulate the phone to receive a call.
- Adjust the volume of the phone audio to be received at a comfortable level. To do this, use the cellular phone volume control (you need to receive a real call to do this) before the ride begins.

- For cellular phones equipped with voice-command dialing, your helmet headset microphone is continually connected to the cellular phone. This will enable the rider or passenger to activate the voice command dialing feature.
- Once a call is received, the rider and passenger headsets will connect to the phone via a distinct VOX activated intercom channel, muting out all lower level communications (music and FRS radio). Phone conversations are then shared by rider and passenger. Any audio generated from the phone or voice input will keep the intercom latched, with a 3.5 second intercom delay from the last VOX input. If a pause in conversation exceeds 3.5 seconds, lower level audio will return until new VOX input is received.
- You may need to fine-tune the cell phone volume until you have established a comfortable volume level while riding. Manipulation of phone controls while riding is not recommended.

**Note: 1** When using a minority of cell phone providers / systems you may hear a slight buzz in the helmet headset when cellular phone activation occurs. This buzzing noise is normal and can be reduced or eliminated by placing the cellular phone as far away as possible from the Integratr IV.

## **FRS / GMRS Two-Way Radio**

- The Integratr IV provides a port to connect FRS / GMRS radio's of various types such as Kenwood FreeTalk™ with corresponding adapter cable JMSR-AC16 or Motorola " T Series " with corresponding adapter cable JMSR-AC15.

### **Operation**

- We recommend reading the owners manual provided with your FRS / GMRS radio to take full advantage of the features and benefits.
- Connect the FRS radio cable to the radio and the accessory jack (K). Turn the FRS radio "on".
- We recommend placing the radio on your belt / riding suit waistband or other remote location.
- Adjust the volume of the FRS radio to be received at a comfortable level. Use the FRS radio volume control to do this (you need to receive a real transmission to do this) before the ride begins.
- Incoming FRS radio transmissions will activate the intercom system, mute the music (Level 1), and will be heard by rider and passenger. Rider and passenger can discuss what is being heard from the FRS radio without that conversation be transmitted.
- To transmit, rider or passenger must press the PTT button.
- The 3.5 second delay of the intercom system aids two-way radio conversations, since most users don't say "over" when their statements are finished. The 3.5 second delay also provides time to bridge the natural pause that occurs while listeners determine the incoming speech has ended, before they respond.

### **Note:**

If you receive a cell phone call while riding with the FRS radio in use, the cell phone will mute all Level 1 & 2 communications. However, if (out of habit) you press the PTT button while talking on the phone that portion of your phone conversation could be transmitted over the FRS radio.

**Note:**

The range afforded with the FRS radio will vary depending upon terrain, weather conditions, outside sources of interference, etc.

**Audio Warning Device or Navigation (GPS)**

- A Navigation system with audio output signal and / or AWD with audio output signal.
- Navigation audio input cable JMSR-AC04
- AWD audio input cable JMSR-AC05
  
- Mount your AAWD to the motorcycle and connect it to the Integratr IV.
- Mount your GPS to the motorcycle and connect it to the Integratr IV.
- Navigation/Warning devices are Level 4 audio, muting all other forms of communication only in the right speaker of the helmet headset. Therefore, the left speaker will still be playing whatever audio is being used, but the right speaker will play the warning tone or Navigation (GPS) spoken directions.

Use of Accessory Audio Warning Devices may not be approved in all States. Please consult and observe all local regulations.

**JMSR-4020 Parts Listing****Main Kit**

JMSR-4010	Main Control Unit (No Battery Tray or Pouch)
JMSR-AC13	Replacement Leatherette/Vinyl Belt Pouch
JMSR-AC10	Replacement Alkaline Battery Tray
JMSR-AC01	Replacement Aux Audio Input Cable

**Accessories**

JMSR-AC02	Cell Phone Input Cable
JMSR-AC03	Remote PTT/Mute Switch Assembly (Handlebar Wrap) with Passengers Extension Cable
JMSR-AC04	Navigator/GPS Audio Input Cable
JMSR-AC05	Audio Warning Device (Radar) Input Cable
JMSR-AC09	Complete Charging Kit (120/240v AC, 12v DC Auto) For Polymer Lithium Ion Battery Pack (International Adapters Included)
JMSR-AC11	Polymer Lithium Ion Battery Pack
JMSR-AC15	Two-Way Radio Connection Cable for Motorola T-Series FRS/GMRS Radios
JMSR-AC16	Two-Way Radio Connection Cable for Kenwood Freetalk FRS Radio
JMSR-AC23	12 Volt DC Power Adapter Pack
JMSR-AC92	3-Pin to 4-Pin Cell Phone Adapter Cable (Nokia)

## **Noise and Interference**

Motorcycle audio systems are by their very nature noisy. While we do not guarantee this system to be completely free from electrical noises and interference, we have taken many steps to achieve that goal: the power supply system is well filtered and the cables associated with the unit are shielded.

Thank you for the confidence you have shown by purchasing one of J&M's innovative products. If you have any questions during installation, or require further assistance, you may call us at 1-800-358-0881 from 8:00 a.m. to 5:00 p.m. Mountain Standard Time, Monday through Friday.

---

Thank you for the confidence you have shown by purchasing one of J&M's innovative products. If you have any questions during installation, or require further assistance, you may call us at 1-800-358-0881 from 8:00 a.m. to 5:00 p.m. Mountain Standard Time, Monday through Friday.



® Tucson, Arizona U.S.A.

(800) 358-0881 • [www.jmcorp.com](http://www.jmcorp.com) • [audio@jmcorp.com](mailto:audio@jmcorp.com)